

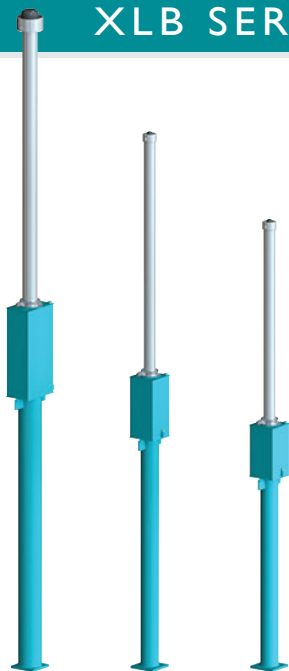

## XLB SERIES INSTALLATION GUIDE



ELEVATOR BUFFERS  
LB 50-60



## 1 SCOPE OF DELIVERY

Oleo buffers are supplied with a standard finish suitable for dry conditions (finished Oleo Green primer). The standard finish is not suitable for wet, corrosive conditions. Special finished buffers are available on request.

Oleo XLB buffers are supplied without oil.

Should there be any discrepancies contact Oleo International before proceeding.

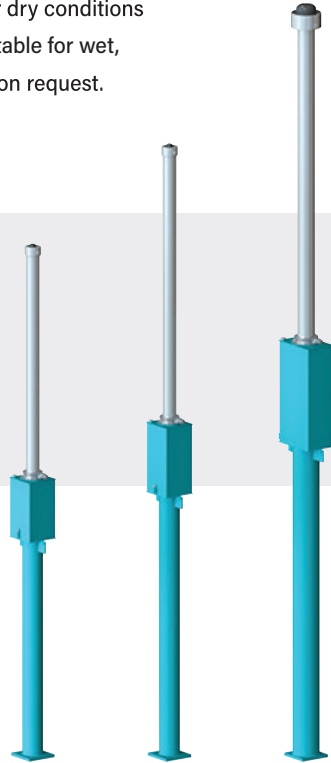

## 2 INDICATION OF USE

Environmental temperature acceptable conditions in line with EN81-20 (0.4.16)  
Ambient Temperatures.

### ! WARNING

The Oleo XLB elevator buffer is supplied containing compressed gas; the plunger is held in the fully compressed condition during transportation by means of a cable, cable clamps and 4 bolts, these should not be removed until the buffer is in its final installed position.

### 3 HANDLING

When handling XLB buffers ensure your regional health and safety laws are adhered to.

Oleo XLB buffers should be positioned using slings, use the following instructions below as guidance:

#### HORIZONTAL CARRYING

The buffer must be fully compressed when manoeuvring.

See *Figure 1* for recommended slinging positions.

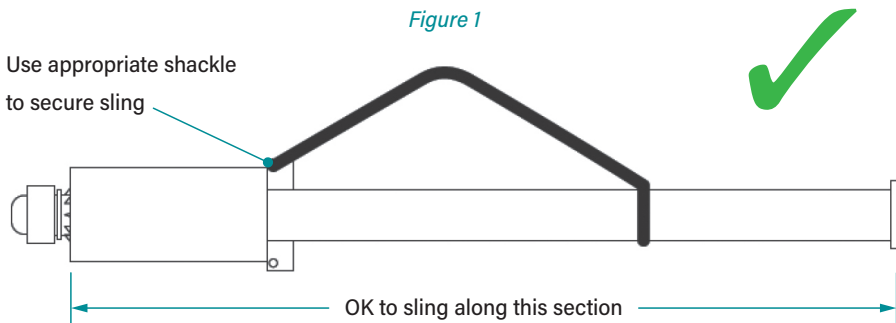

#### ! WARNING

DO NOT sling the buffer extended.

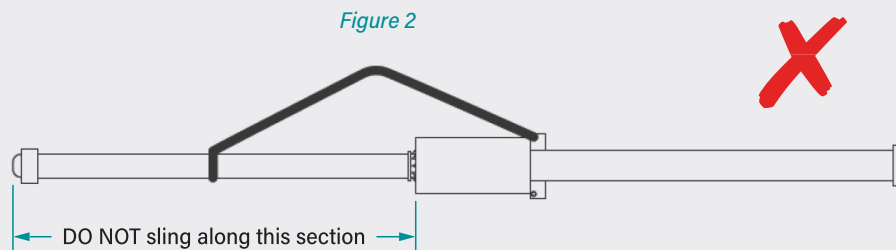

## VERTICAL CARRYING

The buffer must be fully compressed when manoeuvring.

See *Figure 3* for recommended slinging positions.

*Figure 3*

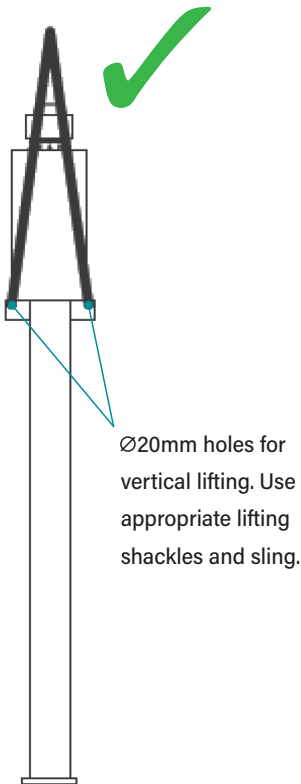

### ! WARNING

DO NOT sling the buffer extended.

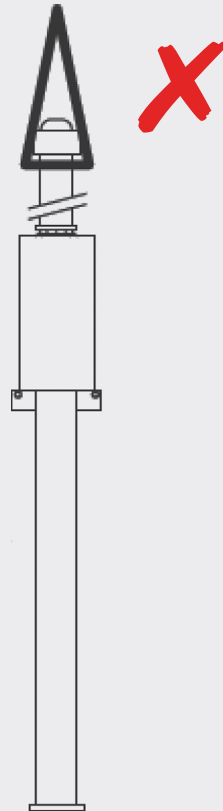

Always confirm the weight of the buffer to be lifted and ensure that a suitable lifting method is used.

## 4 BUFFER WEIGHTS

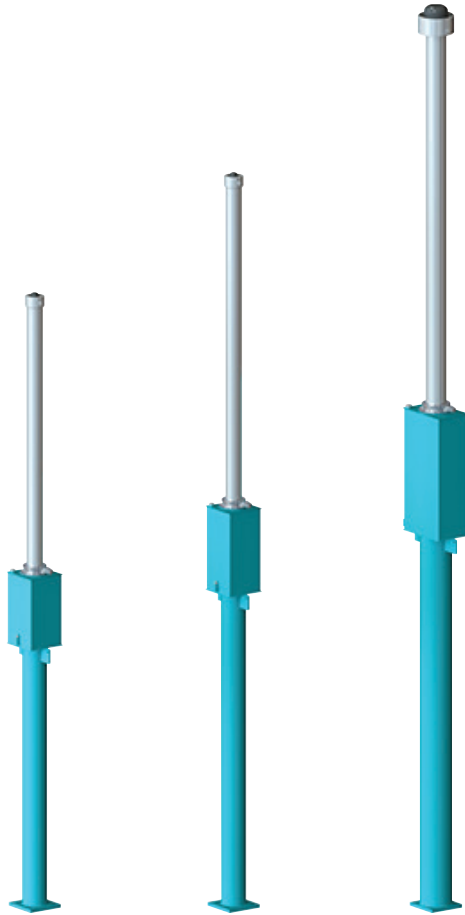

Buffer Model	<b>LB 50</b>	<b>LB 55</b>	<b>LB 60</b>
Without Oil			
kg	202.6	235.2	458.1
lbs	446.7	518.5	1010

## 5 BUFFER INSTALLATION PROCEDURE

Ensure the buffer has been secured into its installation position.

Oleo recommends a bolt size of 20mm for fixing and all four fixing positions are used.

Ensure this area at the base of the buffer, shown in *Figure 4* is supported.

LB 50-55 'X' =  $\varnothing 140\text{mm}$   
LB 60 'X' =  $\varnothing 180\text{mm}$

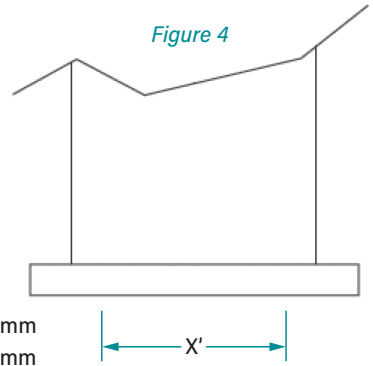

Oleo recommends horizontal supports are used for the installation of LB 50, 55 and LB 60 buffers.

The interface between horizontal support and the buffer should be with the 2 X  $\varnothing 20\text{mm}$  holes on the lifting lugs or below these using a u-shaped bracket (not supplied) around the reservoir tube. See *Figure 5*.

Ensure that the lower car or counterweight carriers will clear the support when the buffer is fully compressed.

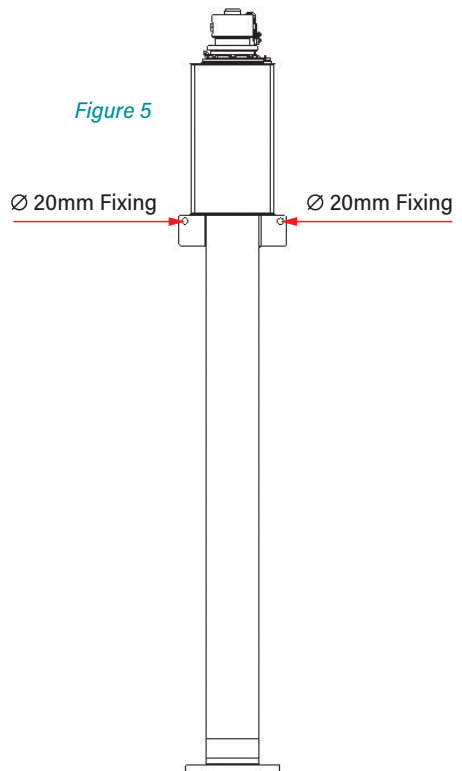

## 5 BUFFER INSTALLATION PROCEDURE Continued

At this point the buffer is still compressed in its transportation state, now the buffer can be released by removing the bolts, clamps and cable, the following is the recommended removal procedure:

For a controlled release, lower the elevator car (or equivalent) onto the buffer.

This mass must be at least equivalent to the minimum mass of the specified buffer.

Minimum mass to compress the buffer shown in table below:

Buffer Model	LB 50	LB 55	LB 60
Minimum Mass			
kg	1500	1250	1500
lbs	3307	2756	3307

### **!** DANGER

Now to release the plunger.

DO NOT Stand over the plunger when releasing. See [Figure 6](#).

Discard transportation bolts, clamps and cable (GREY) shown in [Figure 6](#).

If used, remove the elevator car (or equivalent) and this will control the recoil of the buffer.

After periods of being held in the compressed state during transportation and storage, the plunger may require assistance to initial extend. This should be done using rubber dead blow mallet to tap the underside of the buffer head (GREEN in [Figure 6](#)) at 90 degree intervals until the plunger extends.

Once fully extended the buffer is ready for oil to be added. .

Buffers are to be fitted vertically parallel to guide rail +/-5mm.

*Figure 6*

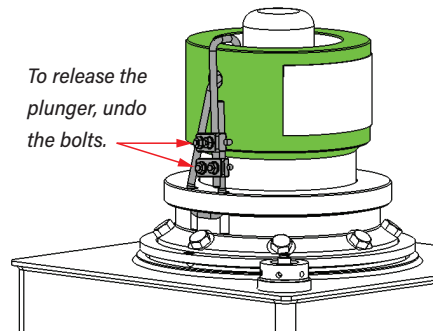

## 6 OIL SPECIFICATION

The oil must conform to the specification on the buffer data plate -

ISOVG68 - SG.88/.90 at 15°C - hydraulic.

Pour Point -18°C or lower.

Viscosity index 75 or higher.

### ! CAUTION

Take care when handling the oils. Observe the oil manufacturers recommendations.

The oil volume guide can be found in table below:

Buffer Model	<b>LB 50</b>	<b>LB 55</b>	<b>LB 60</b>
Approximate Oil Volume			
litres	27.80	33.30	73.00
US Gallons	7.34	8.80	19.28



## 7 LB50 & LB55 OIL FILLING PROCEDURE

### ! NOTICE

The buffer must be vertical and fully extended before filling with oil

### ! CAUTION

Take care when handling the oils. Observe the oil manufacturers recommendations.

- 1 Remove and discard the plastic screw (GREEN) in the centre of the breather valve. See *Figure 7*.

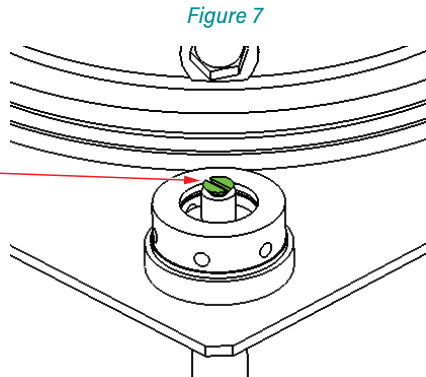

- 2 Unscrew and remove the breather valve - KEEP SAFE.

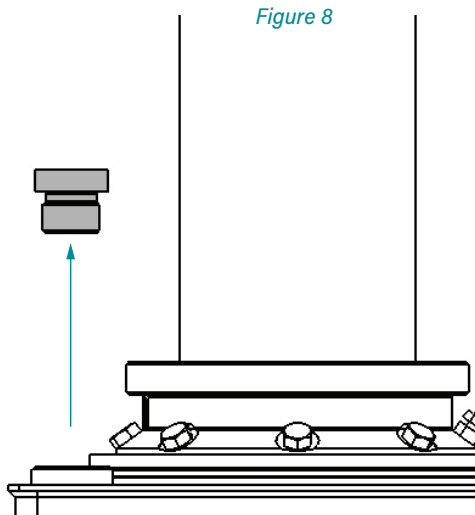

## 7 LB50 & LB55 OIL FILLING PROCEDURE Continued

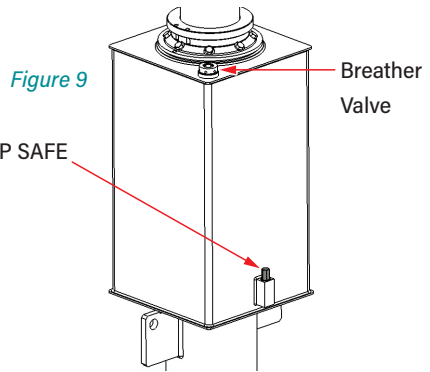

3 Unscrew the dipstick and remove from buffer - KEEP SAFE

4 Gradually fill the buffer with oil until the oil level is visible between the minimum and maximum levels on the dipstick (indicated on *Figure 10*).

5 Allow the buffer to stand for a minimum of 30 minutes.

6 Re-insert the dipstick and screw down.

7 Remove dipstick and inspect level. The oil level needs to be between the minimum and maximum marks indicated on the dipstick as shown in *Figure 10*.

8 Once oil level is correct replace dipstick and securely fasten.

9 Refit breather valve and fasten to 1.7-2.3 N/m (1.25-1.70 lb/ft). As shown in *Figure 9*.

Figure 10

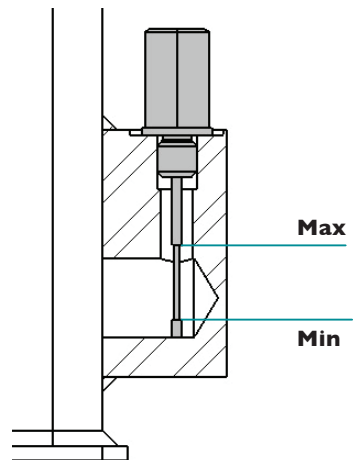

The oil level must be within the correct operating range for the buffer to perform correctly. If further oil is required after checking repeat steps 2-9.

### ⚠ WARNING

DO NOT overfill past the maximum dipstick mark, if this occurs, then oil must be removed from the buffer.

## 8 LB60 OIL FILLING PROCEDURE

### ! NOTICE

The buffer must be vertical and fully extended before filling with oil.

### ! CAUTION

Take care when handling the oils. Observe the oil manufacturers recommendations.

- 1 Unscrew and remove the breather valve (GREY) – KEEP SAFE  
Remove o-ring (GREEN) and discard.

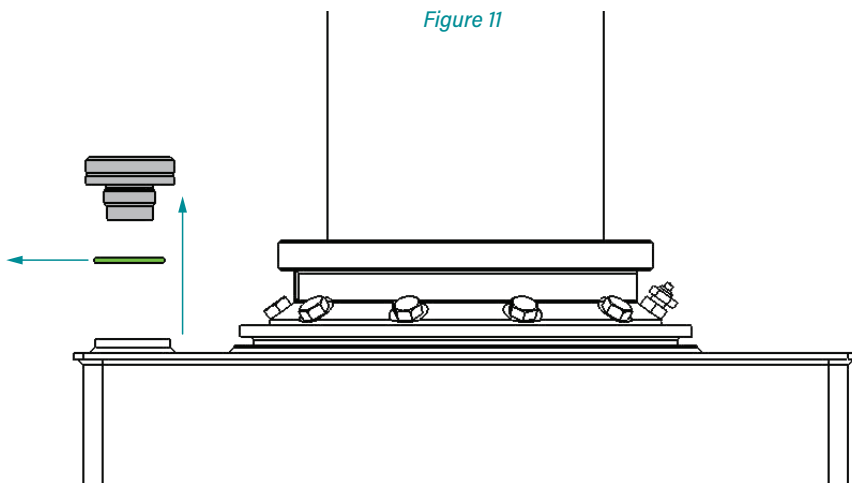

## 8 LB60 OIL FILLING PROCEDURE Continued

Figure 12

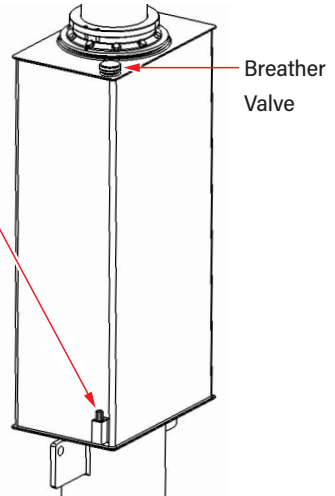

- 2 Unscrew the dipstick and remove from buffer - KEEP SAFE
- 3 Gradually fill the buffer with oil until the oil level is visible between the minimum and maximum levels on the dipstick (indicated on *Figure 13*).
- 4 Allow the buffer to stand for a minimum of 30 minutes.
- 5 Re-insert the dipstick and screw down.
- 6 Remove dipstick and inspect level. The oil level needs to be between the minimum and maximum marks indicated on the dipstick as shown in *Figure 13*.
- 7 Once oil level is correct replace dipstick and securely fasten.
- 8 Refit breather valve and fasten to 1.7-2.3 N/m (1.25-1.70 lb/ft). As shown in *Figure 12*.

Figure 13

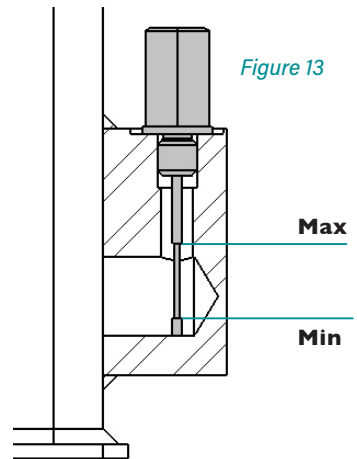

The oil level must be within the correct operating range for the buffer to perform correctly. If further oil is required after checking repeat steps 1-8.

### ⚠ WARNING

DO NOT overfill past the maximum dipstick mark, if this occurs, then oil must be removed from the buffer.

## 9 FITTING SWITCH

Oleo XLB buffers are supplied without the switch fitted. The switch must be fitted before the buffer is commissioned.

Use the following instructions to fit the switch.

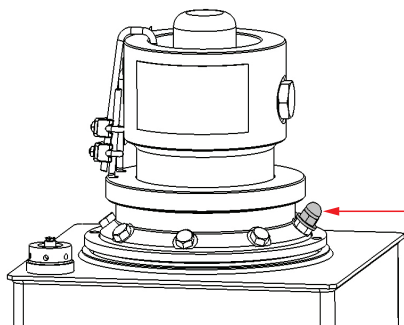

Remove cap and washer, discard.

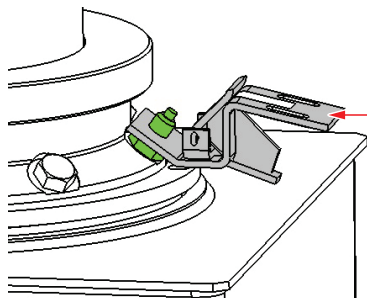

Position bracket assembly (GREY)  
over the threaded spigot (GREEN).

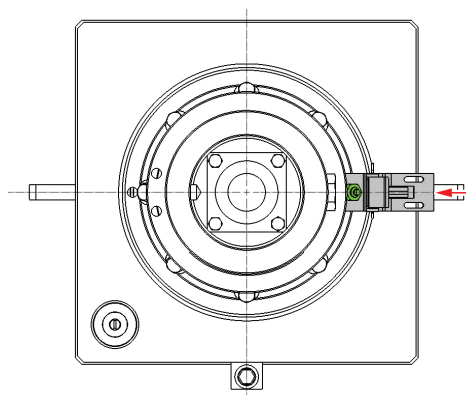

Align bracket assembly with  
centre line of buffer.



## 9 FITTING SWITCH *Continued*

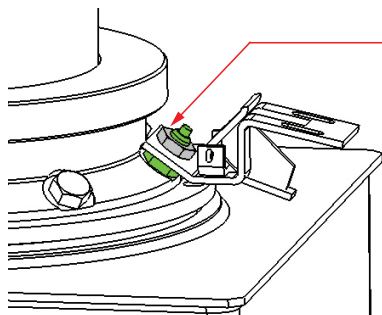

Fit nut (GREY) securely over the threaded spigot (GREEN).

Apply thread lock (eg. Loctite 242/243) tighten nut to 10Nm (8 ft/lbs).

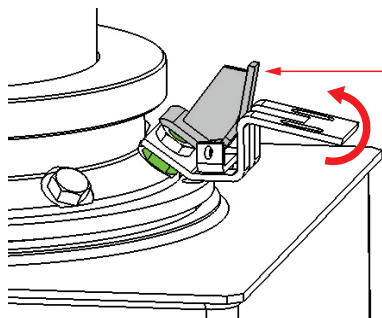

Push lever forward to touch pushrod.

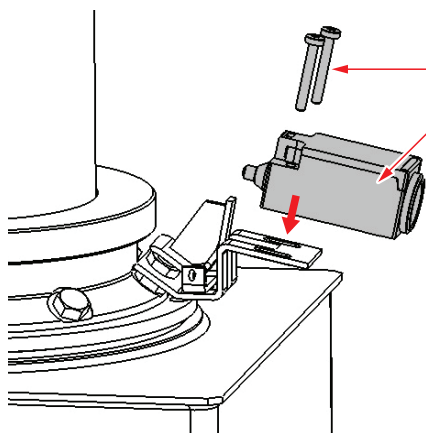

Position switch with screws.

## 9 FITTING SWITCH Continued

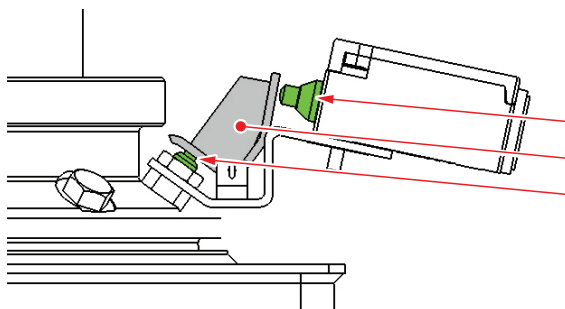

Position switch (GREEN) so lever (GREY) has slight movement between switch and push rod (GREEN).

Ensure no activation is accruing.

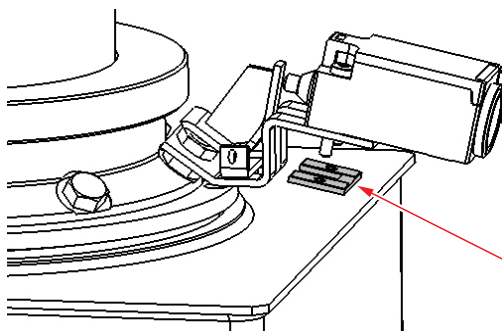

Remove backing from adhesive tape, ensuring the switch is in position; press the sub plate firmly up to the bracket with the 2 screws protruding.

Fit the two washers and nuts to secure the switch.

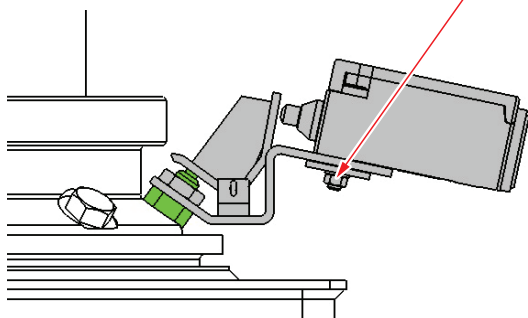

Switch assembly complete.



## 9 FITTING SWITCH Continued

### NOTICE

The switch assembly should appear as follows once installation complete.

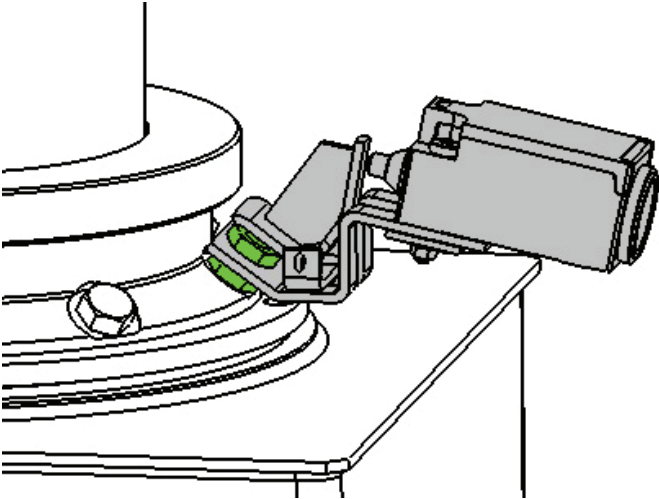



## 10 FINAL COMMISSIONING

Oleo recommends the final 6 step process is followed prior to commissioning:

- 1 Ensure oil level is correct.
- 2 Complete electrical connections to the limit switch.

### ! WARNING

As a safety critical component, buffers should not be installed without a switch

- 3 Compress the buffer at slow speed across its full working stroke then allow to recoil.
- 4 Allow the oil to settle for 30 minutes then check level - see [Section 12](#).
- 5 Finally, impact the buffer at the full rated speed of the elevator.
- 6 Complete final checks of oil level and the buffer is at correct working height.

### ! NOTICE

CHECK: The maximum overall height against the table below.

LB 50 and 55  $\pm 0/-14$ mm of the figure stated.

LB 60  $\pm 0/-15$ mm of the figure stated.

Buffer Model	LB 50	LB 55	LB 60
Extended Height			
m	4.2144	5.0374	6.1796
in	165.921	198.323	243.291

### ! NOTICE

If the buffer has not returned to the fully extended position (determined by measuring overall height) contact Oleo International.



## 11 MAINTENANCE

Oleo recommends the following be carried out every 12 months from installation:

- 1 Clean away debris and dirt from around the plunger and switch.
- 2 Check the oil level is correct. See [Section 12](#).
- 3 Compress the buffer across its full working stroke.
- 4 After the compression, ensure the buffer has returned to its correct working height and visually check for any damage.

### ! NOTICE

CHECK: The maximum overall height against the table below.

LB 50 and 55  $+0/-14$ mm of the figure stated.

LB 60  $+0/-15$ mm of the figure stated.

Buffer Model	LB 50	LB 55	LB 60
Extended Height			
m	4.2144	5.0374	6.1796
in	165.921	198.323	243.291

### ! NOTICE

If the buffer has not returned to the fully extended position (determined by measuring overall height) contact Oleo International.

Ensure regional jurisdictions and laws for maintenance are adhered to.

## 12 OIL CHECKING PROCEDURE

The oil level must be correct and needs to be checked using the following procedure:

- 1 Unscrew the dipstick and remove from the buffer.
- 2 Wipe dipstick clean.
- 3 Re-insert the dipstick and screw down.
- 4 Remove dipstick and inspect level. The oil level needs to be between the maximum and minimum marks indicated on the dipstick as shown in *Figure 14*.
- 5 Refit dipstick and securely fasten.

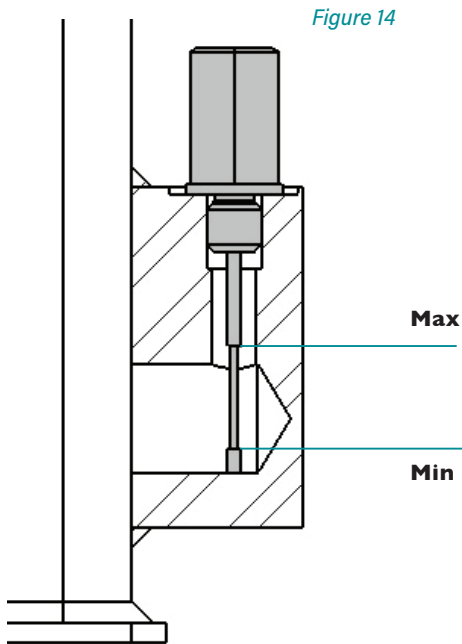

If oil level is incorrect refer to Oil Filling Procedures for the given buffer:

LB50/55 - *Section 7*

LB60 - *Section 8*

### ⚠ WARNING

DO NOT overfill past the maximum dipstick mark, if this occurs, then oil must be removed from the buffer.



**OLEO INTERNATIONAL**

Grovelands  
Longford Road  
Exhall  
Coventry  
United Kingdom  
CV7 9NE

**E** sales@oleo.co.uk  
**T** +44 (0)24 7664 5555  
**F** +44 (0)24 7664 5900  
**W** oleo.co.uk

**OLEO BUFFERS SHANGHAI  
COMPANY LTD**

Plant A15 Xinfei Garden  
No.3802 Shengang Road  
Songjiang  
Shanghai  
201612 China

**E** sales@oleo.cn  
**T** +86 21 6776 0688  
**F** +86 21 6776 0689  
**W** oleo.cn



EUROPE



CANADA/USA



CHINA



KOREA



RUSSIA



ALTERNATIVE LANGUAGE INSTALLATION INSTRUCTIONS ▶



This Installation Guide can be found in the following languages;

**Français**  
French

**Deutsche**  
German

**Español**  
Spanish

**Portuguese**  
Portuguese

**中文**  
Chinese

**Brasileiro**  
Brazilian

**Italiano**  
Italian

**Русский**  
Russian

**한국어**  
Korean

**日本語**  
Japanese

Please visit:

<https://www.oleo.co.uk/downloads/elevator-installation-booklets>